

# DUCTILE IRRIGATION GATE VALVE 9640RT

## Material Specifications

PART NO.	PART	MATERIAL
1	Valve Body	Ductile Iron ASTM A536 65-45-12
2	Resilient Wedge Disc	Ductile Iron ASTM A536 65-45-12+NBR
3	Stem	SS420
4	Bonnet Gasket	NBR
5	Bonnet	Ductile Iron ASTM A536 65-45-12
6	O-Ring	NBR
7	Gland Flange	Ductile Iron ASTM A536 65-45-12
8	Square Operating Nut	Ductile Iron ASTM A536 65-45-12
9	Bolt	Carbon Steel Zinc Plated
10	Flat Washer	Carbon Steel Zinc Plated
11	Ring Wiper	NBR
12	O-Ring	NBR
13	Bolt	Carbon Steel Zinc Plated
14	Axis Guide	Brass HPb59-1
15	Washer	CW617N
16	O-Ring	NBR
17	Bolt	Carbon Steel Zinc Plated
18	Wedge Nut	Brass HPb59-1
19	Seal Ring	NBR

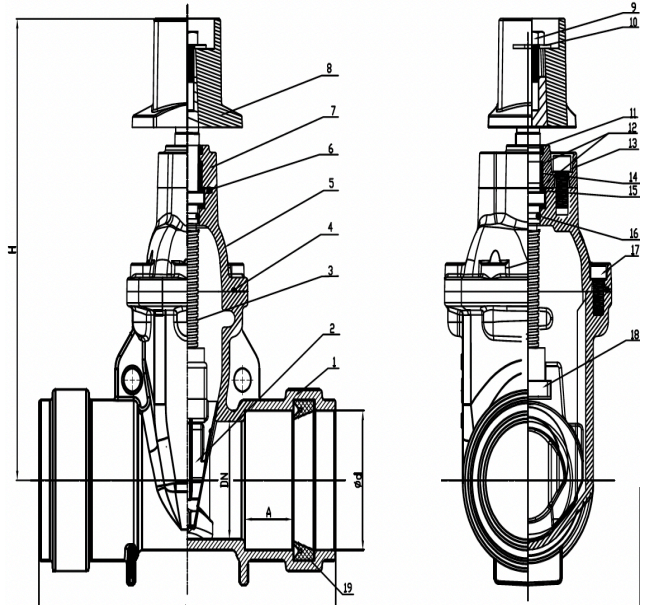

## Notes

- Working Pressure: 300PSI;
- Working temperature: 0 - 100;
- Coating: Fusion Bonded Epoxy Coating Complies with ASNI/AWWA C550.
- Applications: Potable Water, Water Distribution Service & Feed lines, Sewage Disposal, Irrigation
- All dimensions in mm

PART #	SIZE		DIMENSIONS(MM)							
			L		H		A		d	
	inch	mm	inch	mm	inch	mm	inch	mm	inch	mm
9640RT2	2"	50	10.24	260	10.94	278	1.97	50	2.44	62
9640RT25	2 1/2"	65	10.75	273	11.81	300	2.09	53	2.95	75
9640RT3	3"	80	12.01	305	12.64	321	2.24	57	3.56	90.5
9640RT4	4"	100	13.78	350	14.76	375	2.24	57	4.63	117.5
9640RT6	6"	150	16.85	428	17.91	455	3.74	95	6.79	172.5
9640RT8	8"	200	18.50	470	22.24	565	4.65	118	8.74	222